

Infrared heater CIR



⚡ 500-2000 W Electrical heat

12 models



Infrared heater CIR

For applications where discreet design and operation is desired

Application

CIR provide comfort all year around on terraces, balconies and open-air restaurants. CIR can also be used for spot heating in workshops and warehouses. Requires no protection against bad weather and has five-year corrosion warranty.

Comfort

Radiant heaters give an intense, comfortable heat and prolongs the summer season. No moving parts mean a silent system that does not cause air movement or the spreading of dust and other particles.

Operation and economy

Radiant heaters give instant heat, are simple and flexible to install and require minimum maintenance. People and objects are heated but not the surrounding air, which makes radiant heaters very efficient. This is especially effective outdoors. A radiant heater is also more energy efficient, safer and cleaner than a gaspowered heater.

Design

CIR is discreet with its slim design and silent, invisible operation and needs little space to fit in.

Product specifications

- Infrared heater CIR is available in two versions:
 - CIR100 with outputs between 500 and 2000 W.
 - CIR200 with the same outputs and built-in switch.
- Reflectors of high-gloss polished aluminium with maximum resistance against corrosion.
- Grey terminal boxes of heat and weather resistant polycarbonate.
- Adjustable mounting brackets for easy mounting on the wall or ceiling.
- No risk for current leaks and thus no problem with a safety cut-out triggering off.
- IP24. Approved for installation in baths and showers.
- Casing of white lacquered aluminium zinc panels. Colour: RAL 9002, NCS 1502-Y. Protection grille of stainless steel.

Installation height

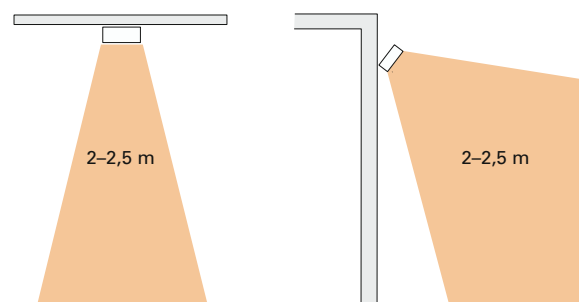

Design and specifications are subject to change without notice.

Infrared heater CIR



CIR is an ideal solution for giving comfort to customers at outdoor restaurants. The heaters can be mounted on the restaurant’s wall or in line directly above the tables in large terraces.



CIR can also be used for spot heating and extra heat contribution.

CIR is easy to fit in with its slim design. The heaters should heat from at least two directions for an even heating.

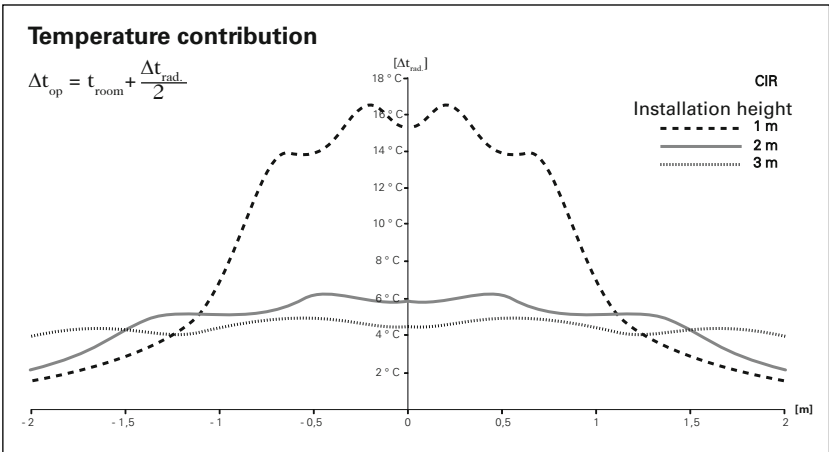

Infrared heater CIR

Technical specifications | Infrared heater CIR100 without built-in switch ⚡

Type	Heat output [W]	Voltage [V]	Amperage [A]	Max. element temperature [°C]	Dimensions LxHxW [mm]	Weight [kg]
CIR10521	500	230V~	2,2	750	710x44x94	1,5
CIR11021	1000	230V~	4,3	750	1250x44x94	2,2
CIR11031	1000	400V2~	2,5	750	1250x44x94	2,2
CIR11521	1500	230V~	6,5	750	1755x44x94	3,0
CIR11531	1500	400V2~	3,8	750	1755x44x94	3,0
CIR12021	2000	230V~	8,7	750	2180x44x94	3,7
CIR12031	2000	400V2~	5,0	750	2180x44x94	3,7

Technical specifications | Infrared heater CIR200 with built-in switch ⚡

Type	Heat output [W]	Voltage [V]	Amperage [A]	Max. element temperature [°C]	Dimensions LxHxW [mm]	Weight [kg]
CIR20521	500	230V~	2,2	750	710x44x94	1,5
CIR21021	1000	230V~	4,3	750	1250x44x94	2,2
CIR21031	1000	400V2~	2,5	750	1250x44x94	2,2
CIR21531	1500	400V2~	3,8	750	1755x44x94	3,0
CIR22031	2000	400V2~	5,0	750	2180x44x94	3,7

Protection class: CIR100 and CIR200: (IP24), splash-proof design.
Approved by SEMKO and CE compliant.

Dimensions

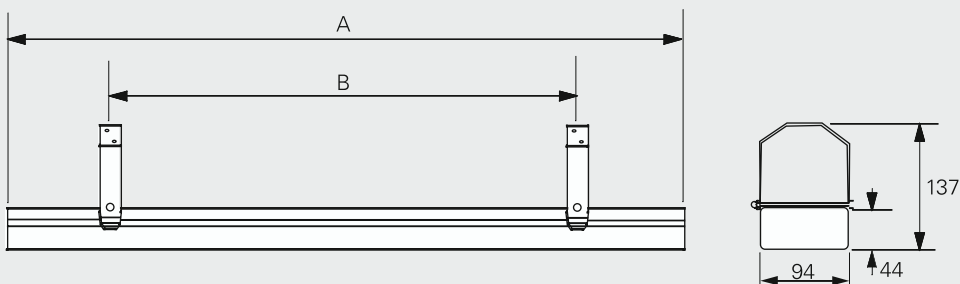

Type	A [mm]	B*1 [mm]	B _{MIN} *2 [mm]
CIR105/205	710	500	300
CIR110/210	1250	900	600
CIR115/215	1755	1200	800
CIR120/220	2180	1500	1000

*1) Recommendation

*2) Minimum distances between brackets

Positioning, mounting and installation

Positioning

The infrared heaters should encircle the area that should be heated, see Fig. 1 and 2. The units are normally positioned 2–3 metres above the ground.

As a general rule, 750-1000 W/m² increases the temperature by approx. 10 °C. The output could be reduced according to how sheltered the terrace is. If the terrace has only a roof at least 1000 W/m² should be installed whereas if the terrace has three walls it should be sufficient with 750 W/m². For a completely closed terrace, the output requirements should be calculated. A green house for example requires 250-300 W/m².

Mounting

Mounting is very easy using the two brackets (supplied as standard), which can be mounted on the ceiling or wall in different angles. When angle mounting CIR on the ceiling, standard brackets can not be used (the distance to the ceiling will be smaller than the minimum distance 150 mm). The distance between the brackets is adjustable and can be chosen according to the most appropriate place for installation. The infrared heaters are snapped into the brackets and then locked in place. CIR can also be suspended from wires. The units should always be mounted horizontally, but can be angled longitudinally. For minimum mounting distance, see Fig. 3.

Connection

CIR is intended for permanent installation. Connection and serial connection of CIR is done with a maximum cable of 4x2,5 mm² + earth.

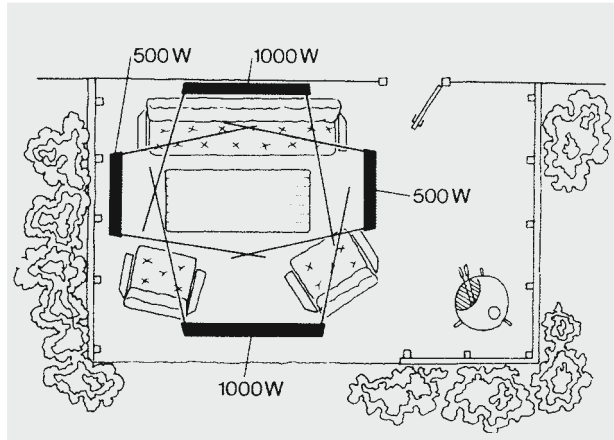

Fig. 1: Good example of positioning, seen from above. Output requirements approx. 1000 W/m².

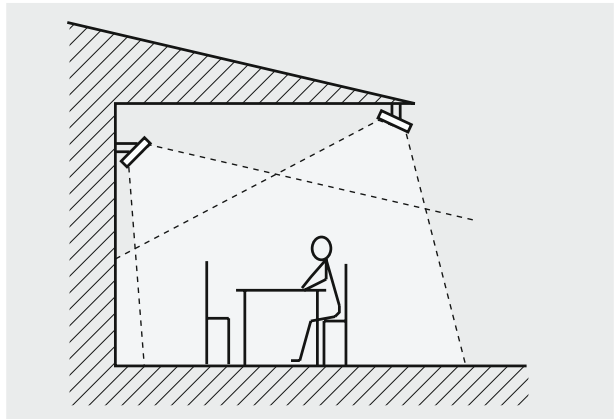

Fig. 2: The heaters should heat from at least two directions for an even heating.

Extra heat contribution

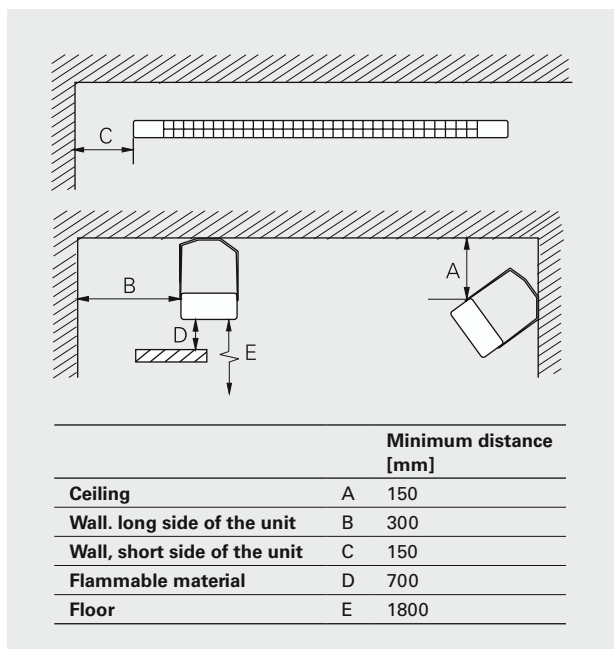
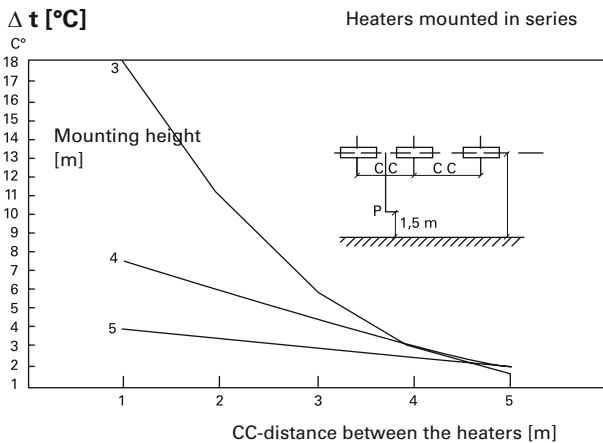

Fig. 3: Minimum mounting distance.

Infrared heater CIR

Control options

Output control with timer

Stepless control especially suitable for spot and zone heating. The heat contribution is regulated for best comfort. Built-in timer is set to desired time.

- CIRT, stepless output control with timer

Control with timer

The timer can be set to desired time. If the load exceeds the timer's setting range or if you want to control a larger system, a contactor can be used.

- CBT, electronic timer

Beside these controls, electric heating control ERP can be used to limit the output indoors or in glassed-in areas.

For further options, see section on thermostats and controls or contact Frico.

Type	Description	HxWxD [mm]
CIRT	Stepless output control	155x87x43
CBT	Electronic timer	155x87x43
ERP	Electric heating control	157x93x40

Wiring diagrams

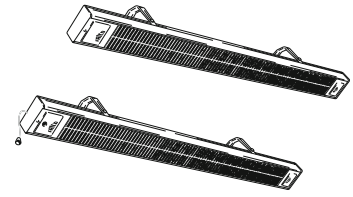

Infrared heater CIR

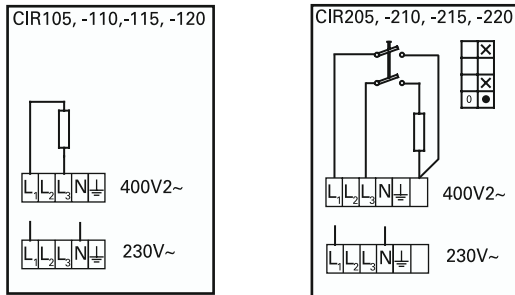

Output control with timer

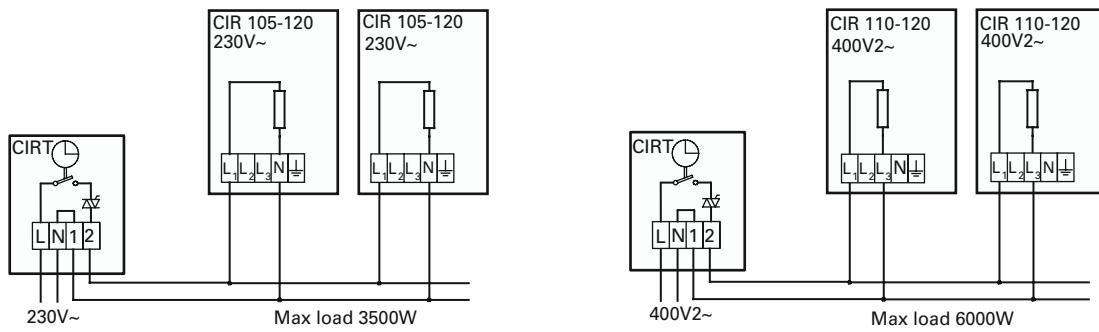

Control with timer

